



UNIQUE COOLING SOLUTIONS

BLACK STEEL

Internal unit

U37BS

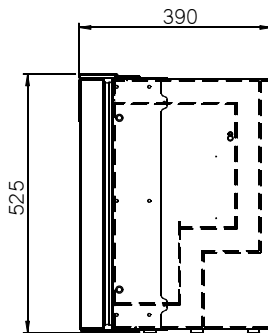
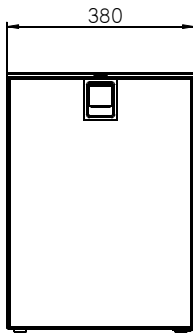

The **U37 BS refrigerator by Uniqool**, part of the **Premium BLACK STEEL** line for marine use, combines **technology and design** to deliver **superior cooling performance and maximum reliability** in marine environments. The cabinet and interior are made from **CNC-machined black ABS**, while the **door, inner panel, balconies, shelves, and interior finishes** are in **stainless steel**, completing an **elegant, corrosion-resistant design**, ideal for nautical applications. It features the **new ultra-compact “Nano” compressor**, providing **maximum cooling power** while minimizing **thermal energy consumption, weight, and noise**. Thanks to **enhanced thermal insulation and tropicalization**, the **U37 BS** operates efficiently up to **+43°C**, ensuring optimal food preservation even under extreme conditions. Its **advanced internal ventilation system, invisible fixing, and stainless-steel positive latch** complete the distinctive features of this model. **The IP65 certification** guarantees resistance to weather conditions and allows cleaning with **high-pressure water jets**.

Refrigerator dimensions (WxHxD): 385x530x400

Total volume: 30 lt

Power supply: 12/24 V DC (110–240 V AC optional)

Thermostat: Manual (standard)
Electronic (optional)

Latch: Stainless-steel positive latch

Interior light: Led

Mounting flange: Optional



BLACK STEEL

Internal unit

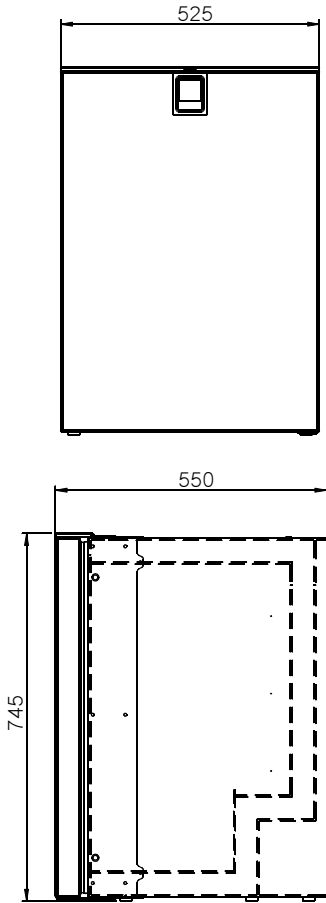

U113BS

The **U113BS refrigerator by Uniqool**, part of the **Premium BLACK STEEL** line for marine use, combines **technology and design** to deliver **superior cooling performance and maximum reliability** in marine environments. The cabinet and interior are made from **CNC-machined black ABS**, while the **door, inner panel, balconies, shelves, and interior finishes** are in **stainless steel**, completing an **elegant, corrosion-resistant design**, ideal for nautical applications. It features the **new ultra-compact “Nano” compressor**, providing **maximum cooling power** while minimizing **energy consumption, weight, and noise**. Thanks to **enhanced thermal insulation and tropicalization**, the **U113 BS** operates efficiently up to **+43°C**, ensuring optimal food preservation even under extreme conditions. Its **advanced internal ventilation system, invisible fixing, and stainless-steel positive latch** complete the distinctive features of this model. **The IP65 certification** guarantees resistance to weather conditions and allows cleaning with **high-pressure water jets**.

Refrigerator dimensions (WxHxD): 530x750x560

Total volume: 115 lt

Power supply: 12/24 V DC (110–240 V AC optional)

Thermostat: Manual (standard)
Electronic (optional)

Latch: Stainless-steel positive latch

Interior light: Led

Mounting flange: Optional



SEAMASTERS

Internal unit

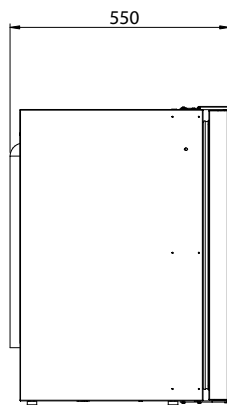
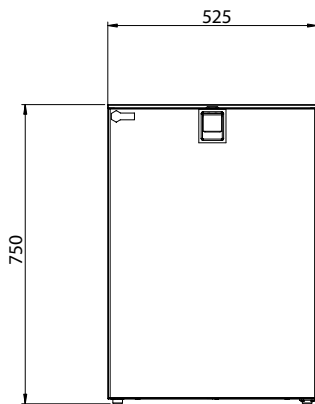

U115SM

The Uniqool U115SM refrigerator, part of the Premium SEAMASTERS line for marine use, is designed to offer superior refrigeration performance and maximum reliability in marine environments, with the advantage of a fully integrated refrigeration unit.

Built entirely in anti-corrosion stainless steel, both internally and externally, and equipped with increased thermal insulation and tropicalization to operate up to +43°C, the U115SM guarantees optimal food preservation even in extreme conditions.

The advanced internal ventilation system, the invisible fastening and the positive closure in stainless steel complete the distinctive features. The IP65 certification attests to its resistance to atmospheric agents and cleaning with water jets.

Refrigerator dimensions (WxHxD):	525x750x550
Total volume:	115 liters
Diet:	12/24 VDC (110-240 VAC optional)
Thermostat:	Manual (standard) Electronic (optional)
Closure:	Positive stainless steel
Interior light:	Led
Fixing profile:	Optional



ARCTIC ARMOR

Internal unit

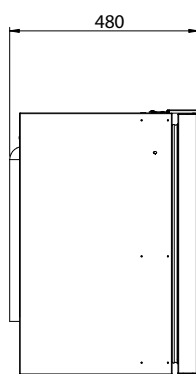
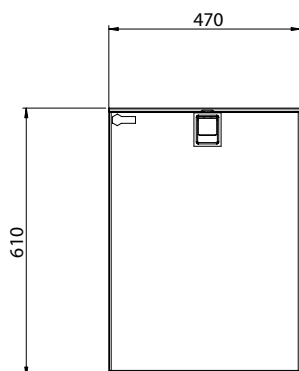

U60AA

The Uniqool U60AA refrigerator from the Arctic Armour series is designed to excel in outdoor kitchens, offering superior refrigeration performance and maximum reliability. Its construction entirely in stainless steel, both internally and externally, guarantees exceptional resistance to corrosion and atmospheric agents.

Increased thermal insulation and tropicalization allow optimal operation up to +43°C, maintaining the internal temperature stable even in extremely hot conditions. **The IP65 certification attests complete protection against dust and water jets, making it ideal for outdoor installation.** Robust, efficient and with a refined design, they are ideal for your outdoor kitchen.

Refrigerator dimensions (WxHxD): 470x610x480

Total volume: 60 liters

Diet: 110-240 VAC 50/60Hz

Thermostat: Manual (standard)
Electronic (optional)

Interior light: Led

Fixing profile: Optional



Available with
remote unit

U75AA

Code:
- U10500004
- U10500007 (GR)



UCS QUICK COLD

Condensing units

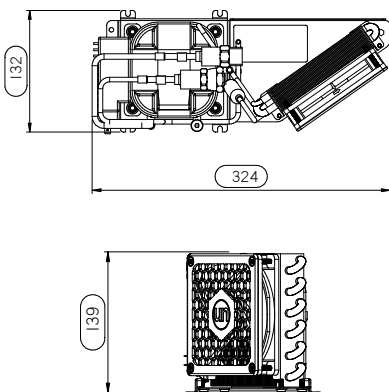
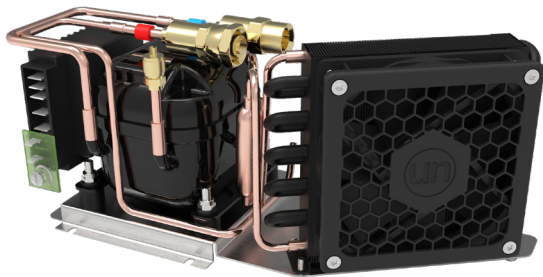
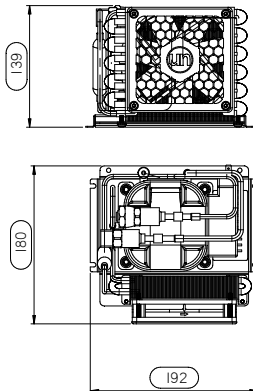
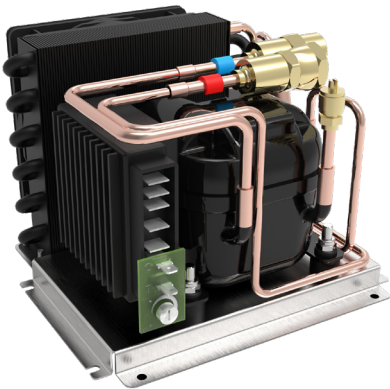

UCS20 Compact Cube

UCS20 Compact Cube Ventilated Refrigeration Unit, Maximum Efficiency in Small Spaces. The UCS20 **Compact** ventilated refrigeration unit, with its extremely **compact** "Cube" design, offers an efficient and versatile refrigeration solution for marine and camper applications. Combined with one of our evaporators, it is ideal for refrigeration of insulated compartments of up to 80 liters (indicative volume for refrigerator application).

Dimensions (WxHxD): 192 x 139 x 180

Maximum refrigerated volume: 80 Liters

Diet: 12-24 VDC (110-220VAC optional)

Refrigerant connection: To be welded (*optional preloaded system with quick couplings*)

Nominal consumption: Max 56 W

Weight: 2,8 kg

Code:
- U10000008
- U10000010 (GR)

UCS20 Compact Slim

UCS20 Compact Slim Ventilated Refrigeration Unit, Maximum Efficiency in Small Spaces. The UCS20 Compact ventilated refrigeration unit, with its extremely compact "Slim" design, offers an efficient and versatile refrigeration solution for marine and camper applications. Combined with one of our evaporators, it is ideal for refrigeration of insulated compartments of up to 80 liters (indicative volume for refrigerator application).

Dimensions (WxHxD): 324x139x132

Maximum refrigerated volume: 80 Liters

Diet: 12-24VDC (110-220VAC optional)

Refrigerant connection: To be welded (*optional preloaded system with quick couplings*)

Nominal consumption: Max 56 W

Weight: 2,8 kg

Code:
- U10000009
- U10000011 (GR)

UCS QUICK COLD

Condensing units

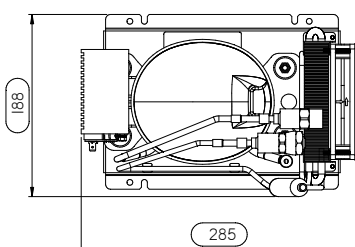
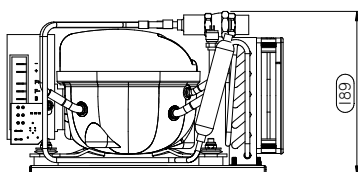
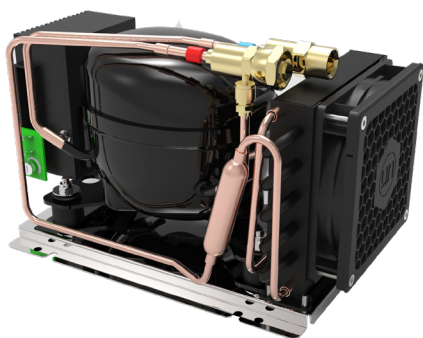
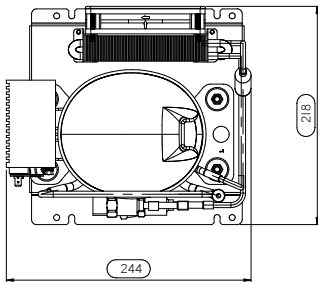
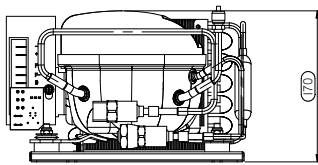
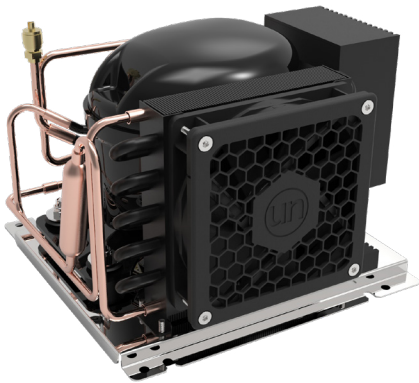

UCS80 Cube

UCS80 Cube Ventilated Refrigeration Unit – Unsurpassed Power for Large Volumes and Extreme Performance. The UCS80 Cube ventilated refrigeration unit is the flagship solution in our range, designed to offer uncompromising refrigeration and freezing performance in marine and camper environments. Ideal for applications requiring maximum refrigeration power and maximum capacity. Combined with one of our high-performance evaporators, this unit can cool insulated compartments of up to 400 litres (refrigerator configuration) and up to 120 litres (freezer configuration).

Dimensions (WxHxD): 244x150x218

Maximum refrigerated volume: 400 liters fridge
120 liters freezer

Diet: 12-24 VDC (110-220VAC optional)

Refrigerant connection: To be welded (*optional preloaded system with quick couplings*)

Nominal consumption: Max 112 W

Weight: 5,9 kg

Code: - U10000004; - U10000006 (GR)

UCS80 Slim

UCS80 Slim Ventilated Refrigeration Unit – Unsurpassed Power for Large Volumes and Extreme Performance. The UCS80 Slim ventilated refrigeration unit is the flagship solution in our range, designed to offer uncompromising refrigeration and freezing performance in marine and camper environments. Ideal for applications requiring maximum cooling power and maximum capacity. Combined with one of our high-performance evaporators, this unit can cool insulated compartments of up to 400 liters (refrigerator configuration) and up to 120 liters (freezer configuration).

Dimensions (WxHxD): 285x169x188

Maximum refrigerated volume: 400 liters fridge
120 liters freezer

Diet: 12-24 VDC (110-220VAC optional)

Refrigerant connection: To be welded (*optional preloaded system with quick couplings*)

Nominal consumption: Max 112 W

Weight: 5,9 kg

Code: - U10000005; - U10000007 (GR)

UCS QUICK COLD

Evaporating units

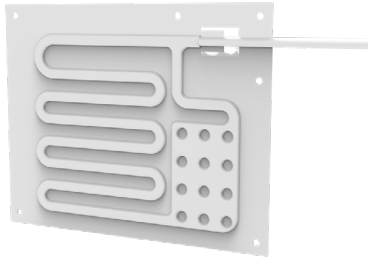

Code:
 - U10200008
 - U10200009 (GR)

EV5

This painted aluminum capillary evaporator represents an efficient and compact solution for refrigeration. Its optimized design maximizes the heat exchange surface, offering significant cooling power in a minimum space, suitable for compartments up to 50 liters (refrigerator configuration).

Dimensions (WxHxD):	250x200x5
Expansion type:	To capillary
Maximum refrigerated volume:	50 liters (refrigerator configuration)
Refrigerant connection:	1,8 mt
Pipe length:	To be welded (<i>optional preloaded system with quick couplings</i>)



Code:
 - U10200000
 - U10200003 (GR)

EV10

This painted aluminum capillary evaporator represents an efficient and compact solution for refrigeration. Its optimized design maximizes the heat exchange surface, offering significant cooling power in a minimum space, suitable for compartments up to 80 liters (refrigerator configuration).

Dimensions (WxHxD):	250x350x5
Expansion type:	To capillary
Maximum refrigerated volume:	80 liters (refrigerator configuration)
Refrigerant connection:	1,8 mt
Pipe length:	To be welded (<i>optional preloaded system with quick couplings</i>)

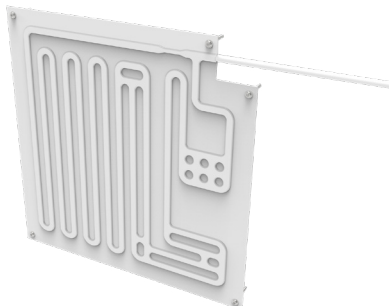

Code:
 - U10200001
 - U10200004 (GR)

EV20

This painted aluminum capillary evaporator represents an efficient and compact solution for refrigeration. Its optimized design maximizes the heat exchange surface, offering significant cooling power in a minimum space, suitable for compartments up to 130 liters (refrigerator configuration).

Dimensions (WxHxD):	350x350x5
Expansion type:	To capillary
Maximum refrigerated volume:	130 litri (refrigerator configuration)
Refrigerant connection:	1,8 mt
Pipe length:	To be welded (<i>optional preloaded system with quick couplings</i>)

UCS QUICK COLD

Evaporating units



EV50

This painted aluminum capillary evaporator offers a powerful and versatile refrigeration solution, designed for larger compartments, up to 200 liters in refrigerator configuration. Its optimized design maximizes the heat exchange surface, ensuring high refrigeration performance in a minimum space. Its main feature is flexibility, thanks to the possibility of folding, which allows to optimize performance even in smaller volumes.

Dimensions (WxHxD): 1056x245x5

Expansion type: to capillary

Maximum refrigerated volume: 200 liters
(refrigerator configuration)

Refrigerant connection: To be welded (*optional preloaded system with quick couplings*)

Pipe length: 1,8 mt

Code:
- U10200002
- U10200005 (GR)

EV20DT

This evaporator is specifically designed for double compartment installations for multi temperature refrigeration systems. Unlike standard models, this evaporator is not equipped with a capillary and must be installed in cascade with other evaporators, such as the EV10 and EV20 models, to create fridge-fridge or fridge-freezer configurations. This configuration allows you to manage different temperatures in two separate compartments, optimizing the preservation of different types of food.

Dimensions (WxHxD): 380x310x5

Expansion type: none (bi-tube)

Maximum refrigerated volume: 100 liters
(refrigerator configuration)

Refrigerant connection: To be welded (*optional preloaded system with quick couplings*)

Pipe length: 1,8 mt

Code:
- U10200006
- U10200007 (GR)

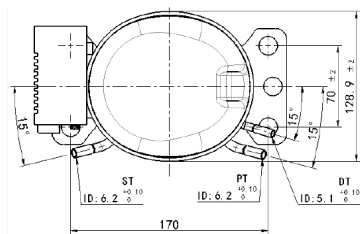
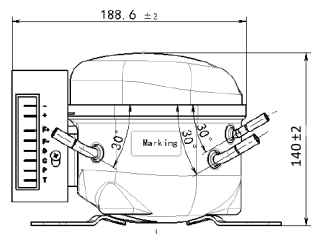
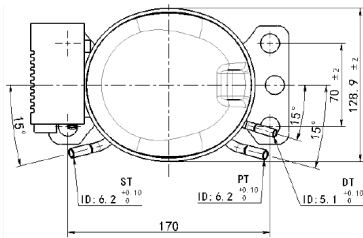
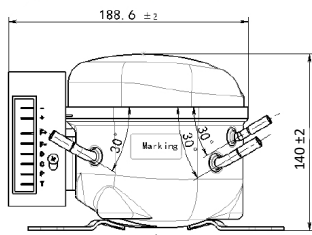

UCS35 Compressor 12/24VDC

Variable speed compressor model L-QDZH30G 12/24VDC R134a suitable for refrigeration of rooms up to 200 lt.
Interchangeable with Secop BD35F and BD50F compressors.

Dimensions (WxHxD):	195x138x128
Diet:	12-24 VDC
Displacement:	3 cc
Refrigeration capacity:	87 W (Ev. -23°C Aschrae)
Application:	L/MBP
Refrigerant gas:	R134a (available a R600a)

Code:
- U10990000

Compressore UCS80 12/24VDC

Variable speed compressor model L-QDZH43G 12/24V R134a suitable for refrigeration of rooms up to 400 lt.

Dimensions (WxHxD):	195x138x128
Diet:	12-24 VDC
Displacement:	4,3 cc
Refrigeration capacity:	138 W (Ev. -23°C Aschrae)
Application:	L/MBP
Refrigerant gas:	R134a (available a R600a)

Code:
- U10990001

UCS QUICK COLD

Refrigeration unit kit



Code:
 - U10300001
 - U1030XXXX (manual thermostat)

Kit Plug & Play Digital SMALL

Refrigeration Kit for Insulated Compartments up to 80 Liters – Reliable Performance, Simplified Installation and “All-Inclusive”. This kit is designed to provide an efficient and reliable refrigeration solution for insulated compartments up to 80 liters in volume. The “All-Inclusive” solution considerably simplifies the installation process, providing all the necessary components in a single package. **It integrates the cooling capacity of the BD35 and BD50F models in a single device.**

Condensing units:	UCS35 Slim GR
Evaporating units:	EV10 GR
Thermostat:	Uniqool Digital Thermostat (manual thermostat option)
Diet:	12/24 VDC
Maximum refrigerated volume:	80 lt (fridge mode)
Number of refrigerated compartments:	1
Max. evaporator-compressor distance	1,8 mt



Code:
 - U10300002
 - U1030XXXX (manual thermostat)

Kit Plug & Play Digital MEDIUM

Refrigeration Kit for Insulated Compartments up to 130 Liters – Reliable Performance, Simplified Installation and “All-Inclusive”. This kit is designed to provide an efficient and reliable refrigeration solution for insulated compartments up to 130 liters in volume. The “All-Inclusive” solution considerably simplifies the installation process, providing all the necessary components in a single package. **It integrates the cooling capacity of the BD35 and BD50F models in a single device.**

Condensing units:	UCS35 Slim GR
Evaporating units:	EV20 GR
Thermostat:	Uniqool Digital Thermostat (manual thermostat option)
Diet:	12/24 VDC
Maximum refrigerated volume:	130 lt (fridge mode)
Number of refrigerated compartments:	1
Max. evaporator-compressor distance	1,8 mt

UCS QUICK COLD

Refrigeration unit kit



Code:
 - U10300003
 - U1030XXXX (manual thermostat)

Kit Plug & Play Digital LARGE

Refrigeration Kit for Insulated Compartments up to 200 Liters – Reliable Performance, Simplified Installation and “All-Inclusive”. This kit is designed to provide an efficient and reliable refrigeration solution for insulated compartments up to 200 liters in volume, prioritizing performance and ease of installation. The “All Inclusive” solution considerably simplifies the installation process, providing all the necessary components in a single package.

Condensing units:	UCS35 Slim GR
Evaporating units:	EV50 GR
Thermostat:	Uniqool Digital Thermostat (manual thermostat option)
Diet:	12/24 VDC
Maximum refrigerated volume:	200 liters (fridge mode)
Number of refrigerated compartments:	1
Max. evaporator-compressor distance	1,8 mt

Kit Plug & Play Digital DUAL ZONE

Dual-Zone Refrigeration Kit: Cools two compartments with a single refrigeration unit. This kit is designed to offer the possibility of cooling two separate compartments using a single refrigeration unit (compressor and condenser). Ideal solution for cooling two separate spaces with different temperature needs with the advantage of optimizing footprint and reducing costs compared to using two separate systems. It is recommended for two refrigerator compartments + refrigerator (50lt + 100lt) or freezer + refrigerator (20lt + 100lt).

Condensing units:	UCS35 Slim GR
Evaporating units:	EV10 GR + EV20DT GR
Thermostat:	Uniqool Digital Thermostat (manual thermostat option)
Diet:	12/24 VDC
Maximum refrigerated volume:	20+100 lt (combined freezer + fridge mode)
Number of refrigerated compartments:	2
Max. evaporator-compressor distance	1,8 mt



Code:
 U10300004
 U1030XXXX (manual thermostat)